

Uninterruptible Power Supply

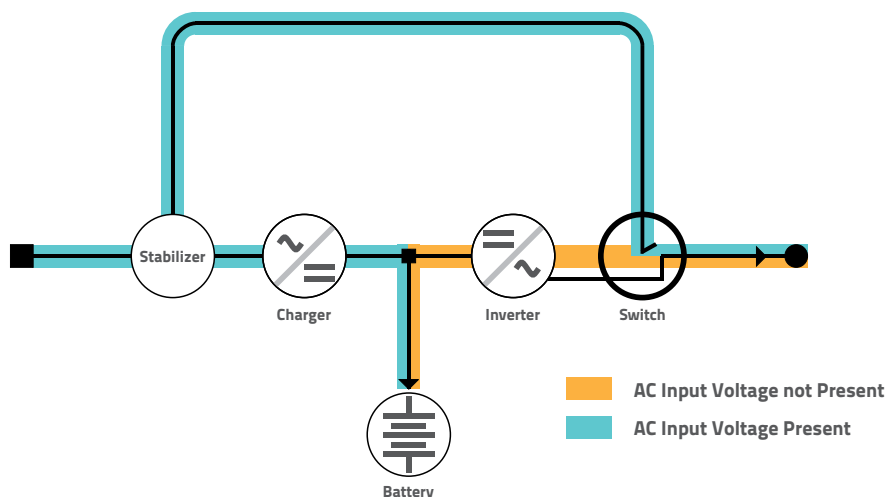

- Compact Design
- Compact Size and Lightweight
- Easy to Use
- EMI / RFI Filter
- Build-in AVR
- High Efficiency
- High Reliability
- Build-in Sealed Lead Acid Battery
- Audible and Visual Indicator
- Support Full Load (EOD)



Protect your computer and sensitive equipments from any electrical disturbance.

ITEM		UNITS	SPECIFICATION		REMARKS
MODEL			CE600	CE1200	
CAPACITY		VA/W	600 / 300	1200 / 600	MAXIMUM
AC INPUT	VOLTAGE	V	160 ~ 250		
	CURRENT	A	1.6	2.9	MAX. LOAD & CHARGER
	FREQUENCY	Hz	50 ± 3		
	PROTECTION	A	3.15	6.3	FUSE
DC INPUT	INTERNAL BATTERY		1 x 12V, 7AH	2 x 12V, 7AH	SEALED LEAD ACID BATTERY
INVERTER OUTPUT	WAVE FORM		SYNTHESIZED SINEWAVE		PWM
	VOLTAGE	V	220 ± 5%		
	FREQUENCY	Hz	50		
	EFFICIENCY	%	> 80		
CHG	TYPE		CONSTANT VOLTAGE		
	VOLTAGE	V	13.5	27.0	
	CURRENT	A	1.5		
TRANSFER TIME		ms	≤ 4		MAXIMUM
BACK UP TIME		min	10		DEPENDING ON LOAD
INDICATOR			LED & BUZZER		SEE TABLE OF CONDITION
OPERATION TEMPERATURE		°C	0 ~ 40		
DIMENSION		mm	345 x 95 x 158	390 x 145 x 195	D x W x H
WEIGHT		Kg	6	12.5	NETTO
			7	14	GROSS

SPECIFICATIONS ARE SUBJECT TO CHANGE WITHOUT PRIOR NOTICE.

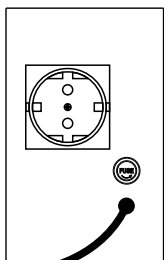

REAR PANEL
UPS CE600

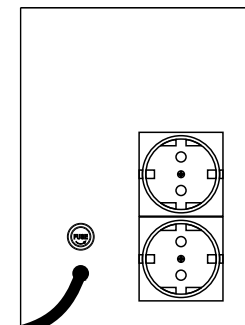

REAR PANEL
UPS CE1200

Contact Person



481-41B0010-110