

# ICAL<sup>®</sup>

## Energy Storage Lithium Battery Module User Manual



**48V100Ah**  
**LiFePO4 Battery Pack**

Battery model: LIP48100LF

## 1 Battery Panel Functions

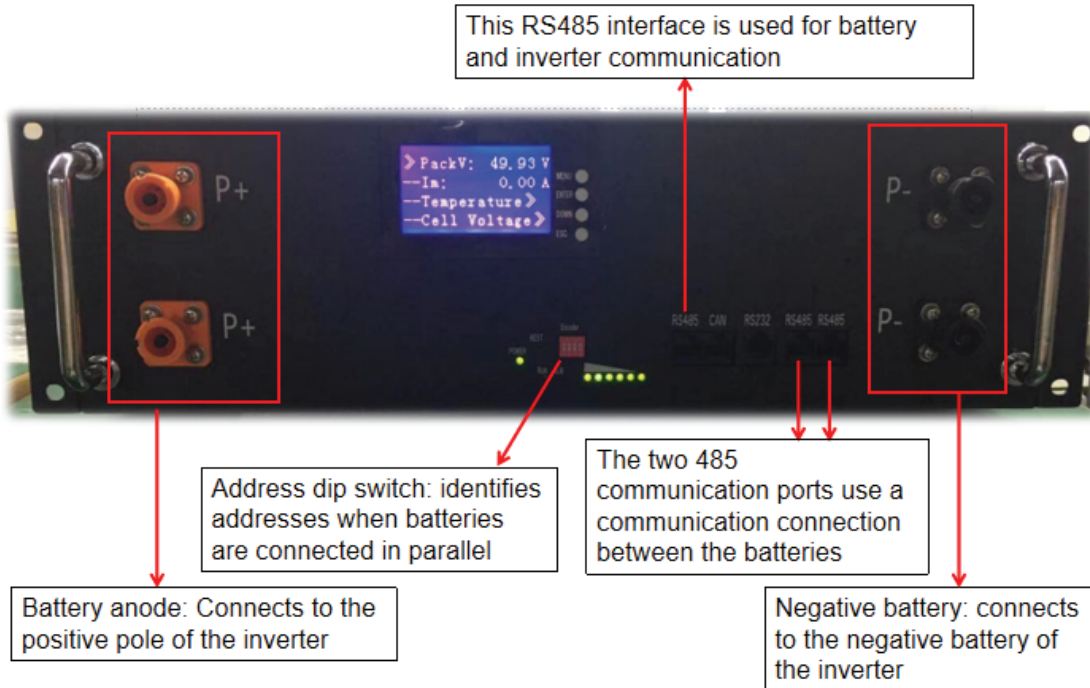

### RUN

**RUN light:** green LED flashing to show the battery running status

### Alarm

**Alarm light:** The red LED blinks to indicate that the battery is alarming, and the red LED blinks to indicate that the battery is protected, as shown in the following table

Battery Running Status	State	RUN	ALM	
		●	●	
Off to Sleep	Dormancy	OFF	OFF	
No Charge and Discharge	Normal	Flash 1	OFF	
	Warn	Flash 1	Flash 3	
Charging Mode	Normal	Light	OFF	
	Warn	Light	Flash 3	
	Overcharge Protection	Light	OFF	
	Temperature or Current Protection	OFF	Light	
Discharge Mode	Normal	Flash 3	OFF	
	Warn	Flash 3	Flash 3	Stop

				charging
	Low Voltage Protection	OFF	OFF	Stop discharging
	Temperature or Current Protection	OFF	Light	Stop discharging

State	Light	OFF
Flash 1	0.25S	3.75S
Flash 2	0.5S	0.5S
Flash 3	0.5S	1.5S

During battery installation or maintenance, you can determine the battery status based on the RUN and ALM displays

## Reset

This reset has the functions of manual wake up and start, manual shutdown and sleep, and reset. Users can flexibly use it according to the actual situation. The specific operation methods are as follows:

1. Manual wake up function: When BMS is in hibernation state, press the button for 3S and release it. BMS will be activated and the battery will return to normal working mode
2. Manual sleep: When the battery is in the normal working state, press the button for 3 seconds and release the button. The battery enters the low-power sleep state
3. Reset function: Press for more than 6s to reset the battery when the battery is in normal working state.

## RS232

It can communicate with the upper computer through RS232 interface and monitor various battery information through the upper computer. The default baud rate is 9600bps.

Pin definitions of the RS232 port	
Pin number	Function definition
Foot 1,2,6	NC
Foot 3	TX
Foot 4	RX
Foot 5	GND

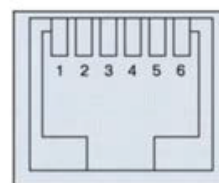

RS232 Port

## RS485

RS485 terminal :(RJ45 port) the RS485 terminal outputs battery information. The default baud rate is 9600bpS. When batteries are deployed in parallel, you need to set the address of each battery using a dip switch.

Pin definitions of the RS485 port	
Pin number	Function definition
Foot 1 and foot 8	RS485-B
Foot 2 and foot 7	RS485-A
Foot 3 and foot 6	NC
Foot 4 and foot 5	NC

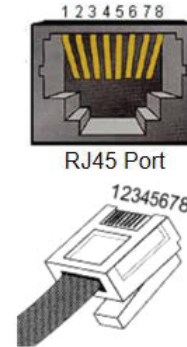

## ADD Switch

If battery strings are connected in parallel and need to communicate in cascading mode, the hardware address of each battery must be configured. The hardware address can be set using the dip switch on the board.

When the batteries are in parallel, address 1 is the host and other addresses are slave. The battery at address 1 is connected to the inverter; If the address is 0, it is in single-battery mode

For details about the switch, see the following table.



Switch Position				Address	Battery Address Definition
1	2	3	4		
OFF	OFF	OFF	OFF	0	PACK 0
ON	OFF	OFF	OFF	1	PACK 1
OFF	ON	OFF	OFF	2	PACK 2
ON	ON	OFF	OFF	3	PACK 3
OFF	OFF	ON	OFF	4	PACK 4
ON	OFF	ON	OFF	5	PACK 5

OFF	ON	ON	OFF	6	PACK 6
ON	ON	ON	OFF	7	PACK 7
OFF	OFF	OFF	ON	8	PACK 8
ON	OFF	OFF	ON	9	PACK 9
OFF	ON	OFF	ON	10	PACK 10
ON	ON	OFF	ON	11	PACK 11
OFF	OFF	ON	ON	12	PACK 12
ON	OFF	ON	ON	13	PACK 13
OFF	ON	ON	ON	14	PACK 14
ON	ON	ON	ON	15	PACK 15

## Schematic Diagram of Battery Parallel Installation

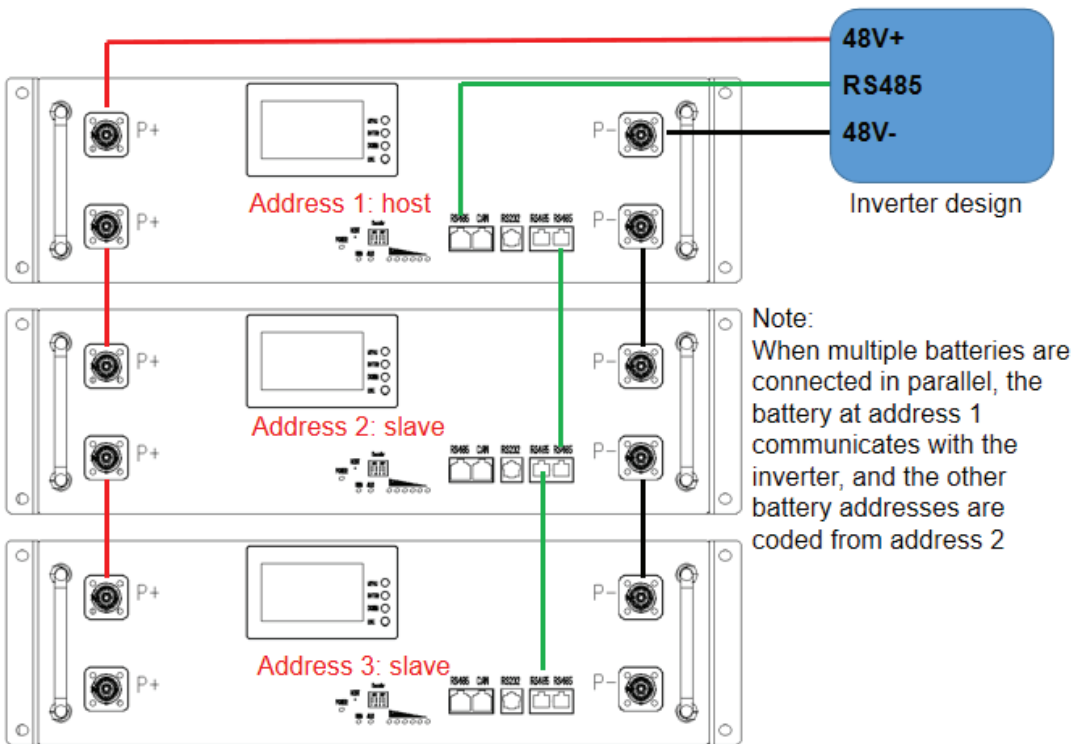

Note: The battery should be turned off during installation. After installation, check OK and then turn on the battery

## 2 Installation Tools

Attention before installation:

2.1 Insulation tools should be used to prevent short circuit during installation.

2.2 Power terminal installation must be checked for tightening, whether there is rust, corrosion or other foreign bodies, if there should be wipe Clean, tighten the bolt, the battery bolt virtual connection will lead to the connection voltage drop is too large, even when the current is large The heat burned the battery.

following tools are required to install the battery module



Electric tools



wire cutter



Crimping Modular Plier

**NOTE:** Use properly insulated tools to prevent accidental electric shock or short circuits. If insulated tools are not available, cover the entire exposed metal surfaces of the available tools, except their tips, with electrical tape.

## 3 Installation Steps

When installing batteries, strictly follow the following steps. Do not change the installation sequence at will

3.1 Before installing the battery, ensure that the battery is powered off or hibernated, If the battery is turned on or woke up, press the "REST" button on the battery panel. Hold down the button for 3 seconds before releasing it. At this time, the battery will enter the hibernation state, and the battery has no voltage output

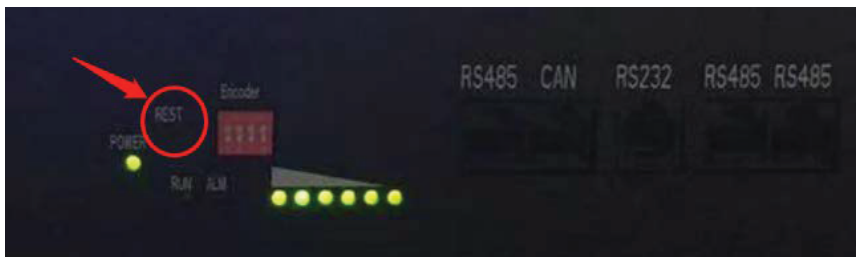

3.2 Place the batteries to be installed into the rack one by one, and install the screws that secure the batteries to the rack

3.3 Connect the negative wires: After the battery is fixed, connect all the negative terminals of the battery together, and finally connect the negative terminal of the inverter DC input to the negative terminal of the battery

3.4 Connect the positive wires: Connect all the positive terminals of the battery. Finally, connect the positive terminal of the inverter dc input to the positive terminal of the battery

3.5 Connect the parallel communication lines: See the figure below

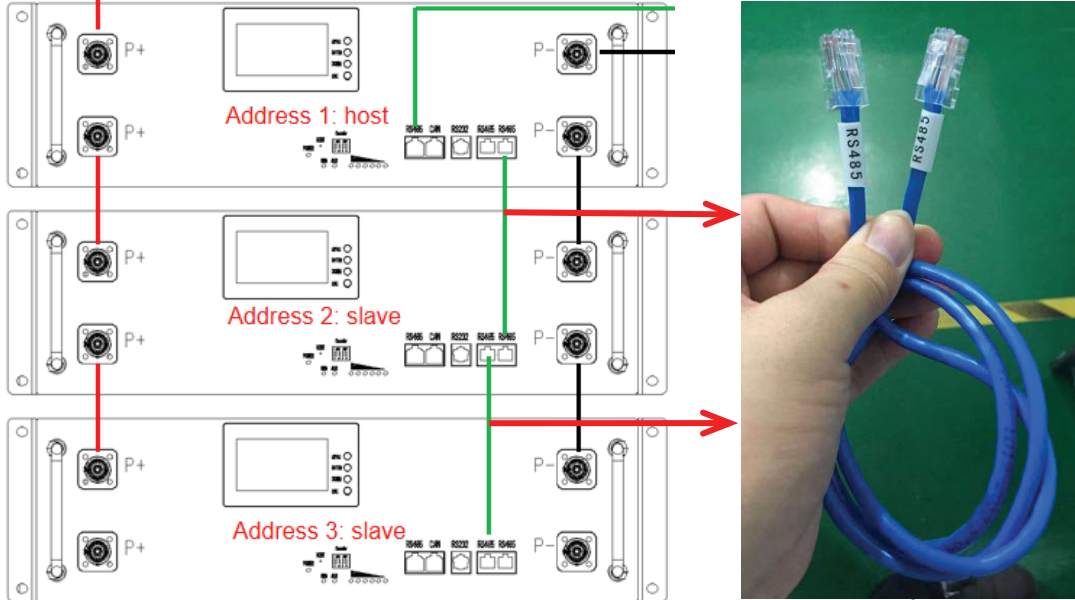

Use this cable to connect the communication connection between the batteries

3.6 Connect the communication cable between the battery and the inverter:

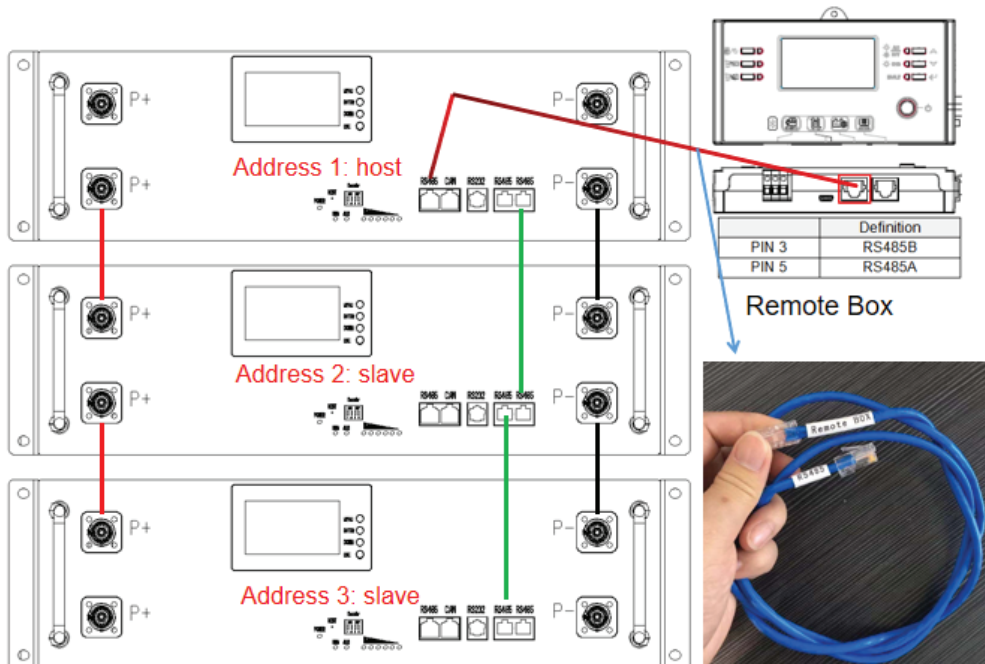



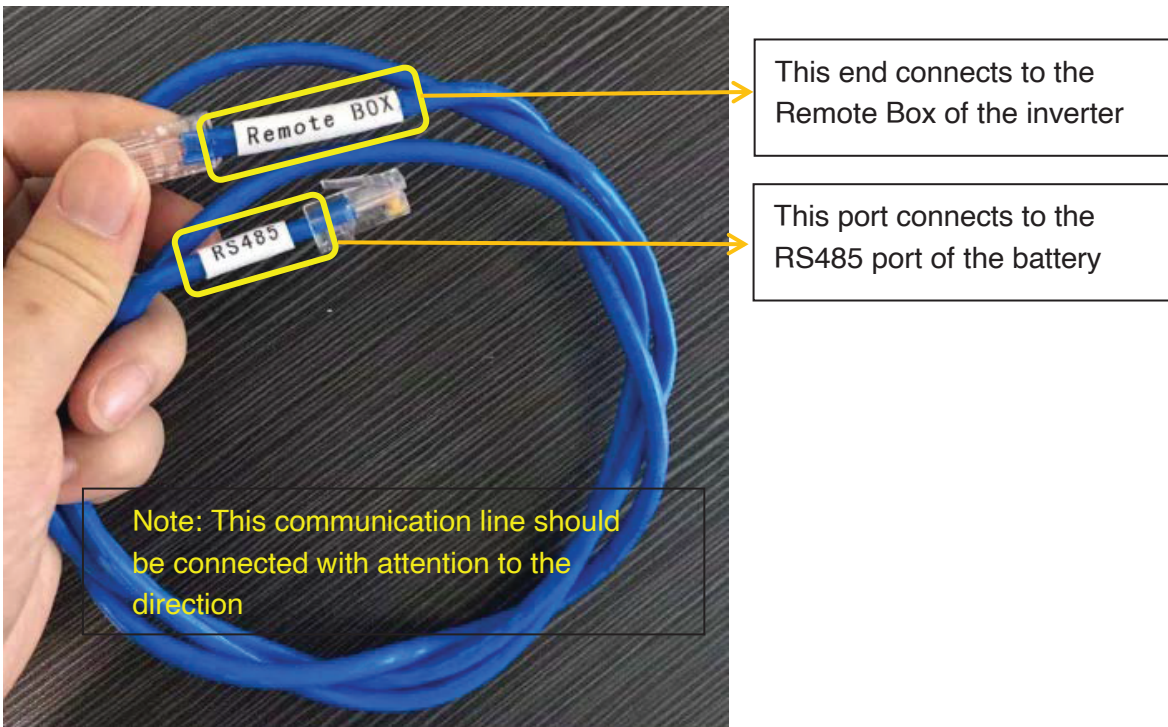

3.7 Setting the Battery Address: After the preceding operations are complete, set the IP address of the battery connected to the inverter to 1, and set other IP addresses from 2 until all the Settings are complete;

Note The address of the battery must not be the same. Otherwise, communication will be affected

3.8 Check that all connections are correct and firm

3.9 Start the inverter to charge the battery. In normal state, all the batteries will be activated and enter the working mode

## 4 Troubleshooting Steps

4.1 Preliminary determination steps:

The battery can be turned on, but red light is lighting, and cannot charge or discharge. If the red light is lighting, that means system is abnormal, please check values as following:

Temperature: Above 55°C or under -20°C, the battery could not work. Solution: to move battery to the normal operating temperature range between -20°C and 55°C

Current: If current is greater than 110A, battery protection will turn on. Solution: Check whether current is too large or not, if it is, to change the settings on power supply side.

High Voltage: If charging voltage above 54V, battery protection will turn on. Solution: Check whether voltage is too high or not, if it is, to change the settings on power supply side.

Low Voltage: When the battery discharges to 44.5V or less, battery protection will turn on. Solution: Charge the battery for some time, the red light turn off . Excluding



the four points above, if the faulty is still cannot be located, turn off power switch of the battery and repair.

#### 4.2 The battery cannot be charged or discharged

4.2.1 No charging: First check that the charging voltage of the charging device is normal, if the charging voltage is normal (52.5V-54.75 V), and then use the upper computer to connect with the battery, read the detailed data of the battery, check whether the voltage and temperature of the single battery are normal, if the charging equipment is normal, the general reason for not charging is: the single charging over voltage protection or high temperature protection.

4.2.2 Fail to discharge: Disconnect the battery from the load and measure whether the voltage of the battery is normal, If the battery has no output voltage, press the Reset button to sleep the battery first and then wake up (restart the battery), and test the battery voltage again. If the battery voltage returns to normal, it indicates that the battery is protected, Check the load.

If there is no voltage output after the battery is restarted, connect the battery to the host computer and check whether the battery voltage and temperature are normal.

Generally cannot discharge the reason is: temperature protection, over current protection, under voltage protection

## 5 Emergency Measures

5.1 Leaking Batteries If the battery module leaks electrolyte, avoid contact with the leaking liquid or gas. If one is exposed to the leaked substance, immediately perform the actions described below.:

- Evacuate the contaminated area, and seek medical attention.
- If the body comes into contact with harmful substances such as electrolytes, wash it thoroughly with soap and water immediately. If you feel unwell, seek medical attention immediately.

5.2 If smoke or open flame is found in the battery, use only a dry powder extinguisher. If possible, the battery should be removed and placed in a safe place before the battery module catches fire to avoid greater damage

5.3 Damaged batteries are dangerous and must be handled with great care. If faulty batteries need to be stored, store them in a special warehouse and take fire control measures

5.4 If the electrolyte of the battery is found to leak, then the battery needs to be scrapped, Contact a professional battery recycling company in your area